

PBV® Series 6322 Sealwelded Ball Valves

Corrosion resistant ball valves for sour oilfield environments.
Ends are sealwelded for zero leak path to atmosphere.

Standard Features

- Full Port: 1/4" - 2", 2000 WOG, 2 1/2" - 3", 1500 WOG, 4", 1000 WOG at 100°F
- 200 psig Saturated Steam
- Full CF8M 316 Stainless or WCB Carbon Steel Body with 316 Stainless Steel Trim
- Elevated Packing Nut for Ease of Access When Automated
- Standard ISO Actuator Mounting Pads on All Sizes
- NACE MRO175 Compliant
- Reinforced PTFE Seats
- 316 Stainless Steel Ball & Stem
- Sealwelded Construction
- Standard Locking Stainless Steel Handle



Specifying Valve Figure Numbers

Example: 2" C-6322-38-2236-GL-NL This number represents a 2" Carbon Steel 6322 Series Two-Piece Sealwelded Full Port Floating Ball Valve with Threaded NPT F X F End Connections, Carbon Steel WCB Body Material with 316 Stainless Steel Internal Trim, Reinforced PTFE Seats, Graphite Seal Material, NACE Compliant with Standard Lever Handle Operator.

C	- 63	22	- 38	- 22	36	- G	L	- N	L
Material Code	Design	Design / Port	End Conn.	Body Material	Internal Trim	Seat Material	Seal Material	NACE Option	Operator
C	63	22	38	22	36	G	L	N	L
Carbon Steel	PBV®	2-Pc.	Threaded	Carbon Steel	316 SS	Glass Filled	Graphite	NACE	Standard
WCB	Sealweld	Sealweld	NPT	WCB	00		PTFE		Lever
S		Full Port	FX F	36	Same as				
Stainless				Stainless	Body				
Steel CF8M				Steel CF8M					

Break Torques (in./lbs.)

Size (in.) Full Port										
1/4	3/8	1/2	3/4	1	1 1/4	1 1/2	2	2 1/2	3	4
50	50	75	120	180	300	400	600	1050	1350	2200

Flow Coefficient (C_v)

Size (in.) Full Port										
1/4	3/8	1/2	3/4	1	1 1/4	1 1/2	2	2 1/2	3	4
10	10	16	32	62	115	140	365	450	1100	2200

PBV® Series 6322 Engineering Data

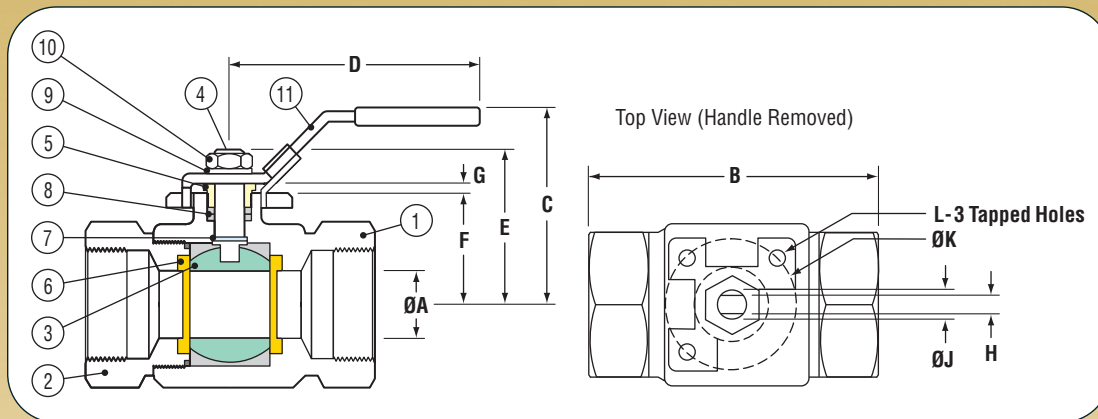

Dimensional Data (in.) & Weight (lbs.)

Size (in.)	ØA	B	C	D	E	F	G	H	ØJ	ØK	L • 3 Tapped Holes (UNC)	ISO Pattern	Weight (lbs.)
1/4-3/8	0.43	2.7	2.2	5.1	1.53	0.78	0.35	0.20	0.31	1.42	1/4"-20	F03	1.1
1/2	0.50	2.7	2.2	5.1	1.53	0.78	0.37	0.20	0.31	1.42	1/4"-20	F03	1.0
3/4	0.81	3.0	2.8	5.7	2.26	1.28	0.38	0.26	0.44	1.65	1/4"-20	F04	1.7
1	1.00	3.6	3.0	5.7	2.49	1.46	0.43	0.26	0.44	1.65	1/4"-20	F04	2.1
1 1/4	1.25	4.0	3.6	7.3	2.92	1.76	0.45	0.35	0.57	1.97	1/4"-20	F05	3.8
1 1/2	1.50	4.5	3.8	7.8	3.18	2.01	0.46	0.35	0.57	1.97	1/4"-20	F05	6.0
2	2.00	5.0	4.4	7.8	3.64	2.37	0.57	0.35	0.57	1.97	1/4"-20	F05	8.7
2 1/2	2.50	6.6	5.0	13.9	4.33	2.88	0.55	0.47	0.75	2.76	5/16"-18	F07	18.0
3	3.00	7.2	5.4	13.9	4.73	3.27	0.53	0.47	0.75	2.76	5/16"-18	F07	26.0
4	4.00	8.6	7.5	18.0	5.73	4.63	0.53	0.67	1.00	2.76	5/16"-18	F07	45.0

Parts & Materials

No.	Qty.	Part Name	Material
1	1	Body	GR.CF8M or WCB
2	1	Adaptor	GR.CF8M or WCB
3	1	Ball	ASTM A276 GR. 316 SS
4	1	Stem	ASTM A276 GR. 316 SS
5	1	Packing Nut	ASTM A276 GR. 316 SS
6	2	Seats	R-PTFE
7	1	Thrust Washer	PTFE
8	2	Stem Packing	Graphite
9	1	Lock Washer	304 Stainless Steel
10	1	Handle Nut	304 Stainless Steel
11	1	Handle Assem.	304 Stainless Steel

Pressure Temperature

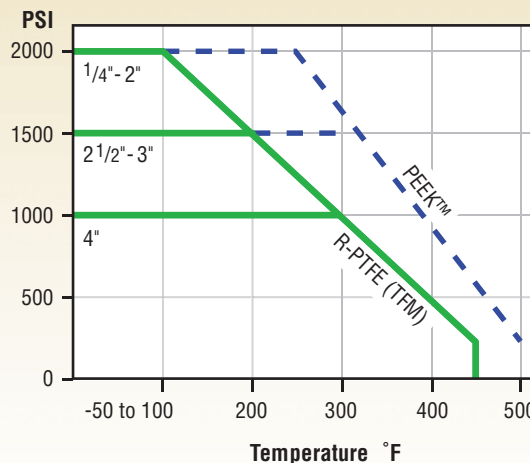

6322

Sealwelded Ball Valve