

Zy-Gear WG108 Worm Gear Operator

Parts And Materials

Item	Part Name	Material
1	Cover	Carbon Steel
2	O-Ring	Nitrile
3	Lock Screw	Carbon Steel
4	Stop Screw	Carbon Steel
6	Hex Bolt	Carbon Steel
7	End Cap	Carbon Steel
8	Bearing	PTFE and Carbon Steel
9	Thrust Bearing	Commercial
10	Worm	AISI 4135
11	Grease Fitting	Brass
12	Pin	Carbon Steel
13	Input Shaft	AISI 4135
14	O-Ring	Nitrile
15	Lock Bracket	Carbon Steel
17	Key	Carbon Steel
18	Lock Plate	Carbon Steel
20	Square Nut	Carbon Steel
21	Handwheel	Carbon Steel
22	O-Ring	Nitrile
23	O-Ring	Nitrile
24	Indicator Plate	Cast Iron
26	Cover	Cast Iron
27	Gasket	Rubber
28	Worm Gear	Ductile Iron
29	Housing	Cast Iron
31	Bushing	Carbon Steel

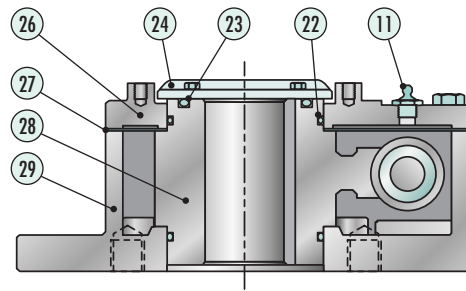
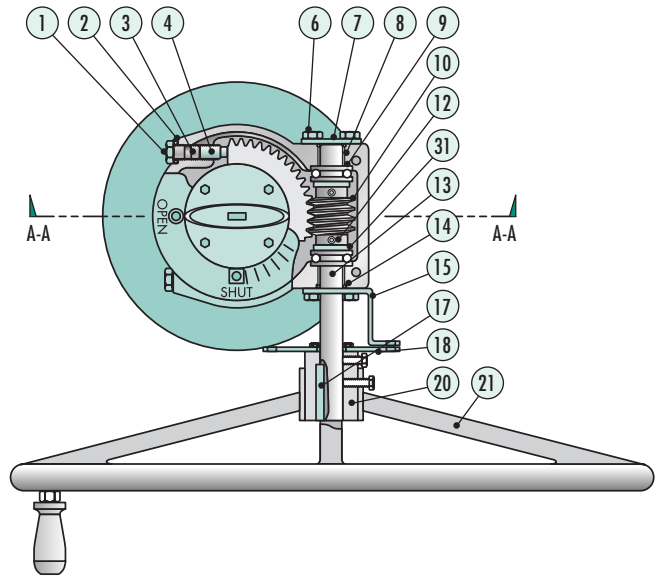

SECTION A-A

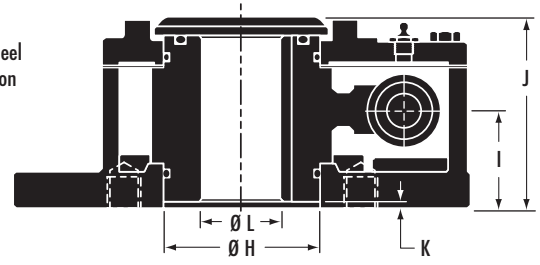
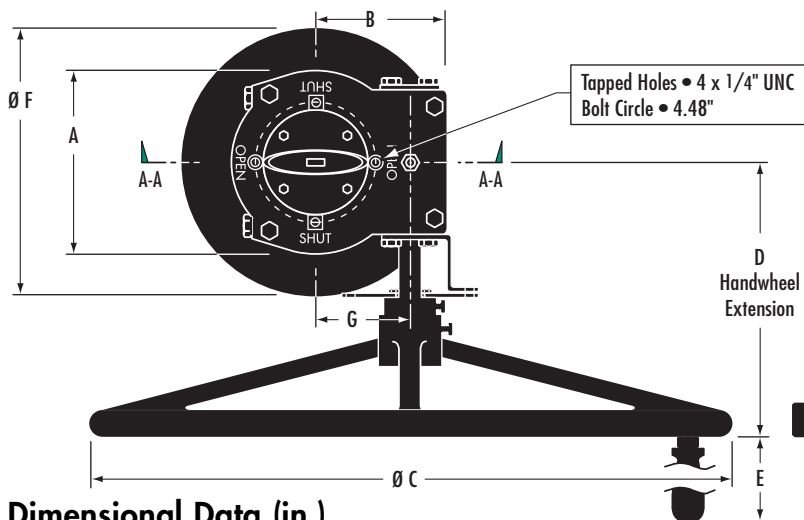

SECTION A-A

Dimensional Data (in.)

Model	Wt. (lb.)*	A	B	C	D	E	F	G	H	I	J	K	L
WG108	44	6.90	4.90	18	11.5	4.00	10.00	3.55	3.45	2.15	4.20	0.14	.80
				24	14.9								
				30	15.9								

*Approximate weight without handwheel.